

مشخصات فنی دیگ آبگرم

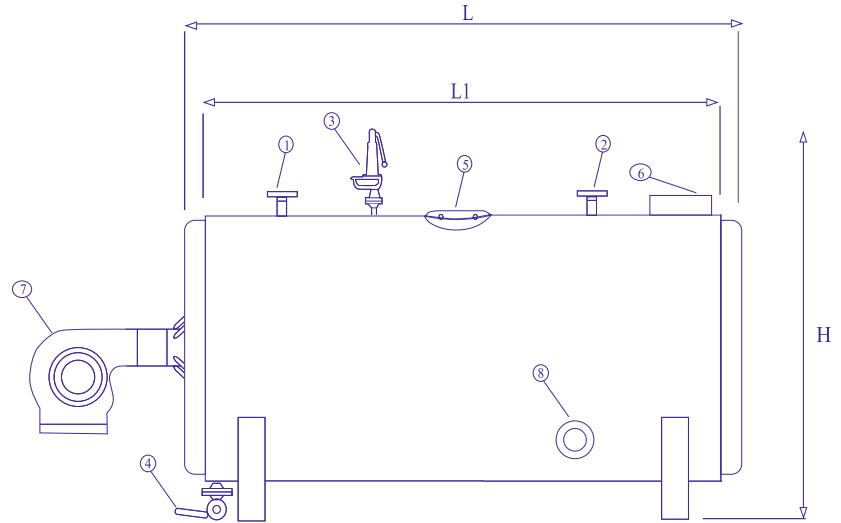
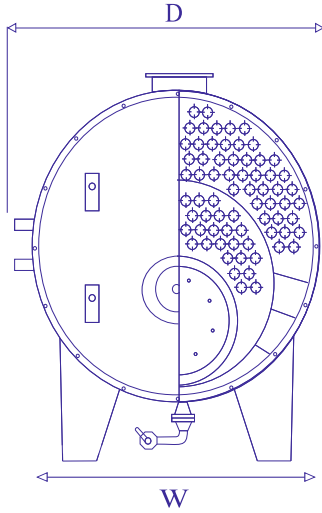

Model		W.B.04	W.B.05	W.B.06	W.B.08	W.B.1	W.B.1.25	W.B.1.5	W.B.2	W.B.2.5	W.B.3
Type		Dry Back	Dry Back	Dry Back	Dry Back	Wet Back	Wet Back	Wet Back	Wet Back	Wet Back	Wet Back
Boiler duty (x 1000 Kcal/hr)		400	500	600	800	1000	1250	1500	2000	2500	3000
Fuel	Fuel oil(kg/L)	50	55	75	100	125	156	165	200	260	340
	Natural gas(m3/hr)	40	50	60	80	100	125	150	200	250	300
Overall length (mm)	L	2750	2900	3150	3450	3650	3800	4000	4200	4500	4800
Shell length (mm)	L1	1850	2000	2200	2500	2700	2800	3000	3200	3400	3600
Boiler dia (mm)	D	1100	1150	1200	1250	1350	1400	1450	1500	1600	1700
Total width (mm)	W	900	950	1000	1020	1060	1100	1150	1200	1300	1400
Overall height (mm)	H	1500	1550	1600	1650	1750	1800	1900	1950	2100	2200
Connections	Water flow	100	100	100	125	125	150	150	200	200	250
	Water return	100	100	100	125	125	150	150	200	200	250
	Safety valve	50	50	50	65	65	80	80	100	100	125
	Blow down	32	32	32	40	40	40	40	50	50	50
	Vent	25	25	25	32	32	32	32	40	40	40
Water content (m3)		0.83	1	1.2	1.5	2.1	2.3	2.5	2.9	3.1	3.7
Empty weight(kg)		1420	1550	1810	2260	2600	3050	3500	4400	5300	6200
Operating weight(kg)		2250	2550	3010	3760	4700	5350	6000	7300	8400	9900

- 1- Water Flow
- 2- Water Return
- 3- Safety Valve
- 4- Blow Down Valve
- 5- Man hole
- 6- Stack
- 7- Burner
- 8- Hand hole